



INVITATION FOR BID

CITY OF SANTA ANA

IFB DATE:	1-24-12
BID NO:	12-013
BID DUE:	2-06-12, 2:00 PM

PURCHASING DIVISION M-16
20 CIVIC CENTER PLAZA, RM. 429
SANTA ANA, CALIFORNIA 92701

e-mail:Kmontgomery@santa-ana.org
BUYER: Katie Montgomery
(714) 647-5466

INSTRUCTIONS

1. Bid must be on this form.
2. Bid each item separately.
3. Read the instruction, terms and conditions.
4. Direct correspondence / inquiries to the Buyer.
5. Bid the lowest net price, F.O.B. destination, site emplaced.
6. Bids due at other than 5:00 pm will be opened at or immediately following the due time.

Note:
The successful bidder must comply with S.A.M.C. Chapter 21 regarding payment of Business License Tax.

PAYMENT TERMS _____
ESTIMATED START OF PROJECT _____

REQUIREMENTS AND SPECIFICATIONS:

CORBIN CENTER RE-ROOFING PROJECT

The City of Santa Ana invites sealed offers to clean, prepare and restore existing roof at the Corbin Center by applying 2" of BASF polyurethane foam roofing and UNISIL HS United Coatings silicone coating with granules in wet base coat, as described in the attached specification to conform to a Class A system under UL 790. A valid State of California General Contractor's license is required for this work and license number MUST be list below and submitted with offer.

A MANDATORY JOB WALK will be held on **Monday, January 30, 2012 9:00 AM.** Report to the Corbin Center at 2215 W. McFadden Avenue, Santa Ana CA 92704. Parking available at center. Bids submitted from contractors who do not attend the job walk will not be accepted. Prior to job walk, please contact Katie Montgomery at 714-647-5466, to confirm job walk attendance.

CORBIN CENTER RE-ROOFING PROJECT...TOTAL COST \$ _____ detail per page 16.

**** NOTE **** The City reserves the right to reject any and all bids and to waive any informality in any bid. The City reserves the right to award no contract at all.

CA State GENERAL Contractors License No.	Class	Expiration Date
--	-------	-----------------

DUE DATE: Sealed bids are due by 2:00 P.M. on or before February 6, 2012. All bids shall be delivered to the Purchasing Division, Santa Ana City Hall, 20 Civic Center Plaza, Room 429, Santa Ana, California 92701. Bids delivered to any other location or delivered after 2:00 P.M. on February 6, 2012 will be considered nonresponsive and not considered.

TOTAL QUALITY SERVICE and CERTIFICATION OF NONDISCRIMINATION BY CONTRACTORS: Complete and return forms in offer. Failure to comply with statements submitted may result in termination of the contract.

***** MARK ENVELOPE FACE: "SEALED BID IFB 12-013 DO NOT OPEN WITH REGULAR MAIL: *****

Only **SEALED BIDS** are acceptable. **DO NOT FAX OR E-MAIL.**

- "Time Certain": Bid must be received ONLY in the Purchasing Division Office, 4th floor, room 429 prior to BID DUE time. Bids are acceptable if mailed using the U.S. Postal Service or any courier. Any submittal using the night depository WILL NOT BE ACCEPTED.
- Unsigned bids and rubber-stamped signatures MAY BE CONSIDERED NONRESPONSIVE. All original bids MUST BE SUBMITTED IN INK, returned in the enclosed envelope, and contain no correction fluid, tape, or like application.

Page 1 of Page(s)

Council Action

BIDDER'S STATEMENT: I have read, understand, and agree to the terms and conditions on all pages of this Invitation For Bid. Upon request, I will transfer and deliver goods to the City in accordance with said terms and conditions.

COMPLETE THIS SHEET AND RETURN WITH OFFER.

_____	Complete Legal Name of Company	_____	Phone No.	_____	FAX No.
_____	Business Address Street	_____	City/ State	_____	Zip Code
_____	Signature of Authorized Agent - Title	_____	Printed Name	_____	

e-mail address

BID INSTRUCTIONS

1. **ALTERNATIVES:** Any changes or alternatives must be set forth in a letter attached to this bid. The City has the option of accepting or rejecting any alternative bid. Brand names, if any, are given for quality control only. Bids on "equals" are encouraged, however, the bidder must give evidence of equal utility and quality.
2. **REJECTION:** The City reserves the right to reject any or all bids and to waive any informality in any bid.
3. **PERIOD OF ACCEPTANCE:** Unless otherwise stated, bids shall be subject to acceptance by the City for a period of ninety (90) calendar days following the opening of bids.
4. **SAMPLES:** When required, bidder shall furnish samples of items free of expense to the City, and if not destroyed by test may, upon request made at the time the sample is furnished, be returned at the bidder's expense.
5. **TAX:** The City is exempt from Federal Excise Tax. Bidder shall show as a separate item California State Sales and/or Use Tax.
6. **ALL OR NONE BIDS:** The City reserves the right to make an award based on partial items unless the bid submitted by the bidder is marked "ALL OR NONE."
7. **BONDS:** When deemed necessary by the City, Bid Bonds shall be furnished by all bidders in the amount of at least 10% of the bid, to guarantee that bidders will enter into contract to furnish goods at prices stated. Likewise, a Performance Bond shall be required of the successful bidder when stated in the Specification. (Cash deposit, Certified or Cashier's check or Money Order may be submitted in lieu of either Bond). **Not required for this bid.**
8. **TERMS OF PAYMENT:** Payment terms will be considered "NET 30 days" unless a cash discount is offered for earlier payment. Cash discounts may be considered in evaluating the bid price.
***Note: The City is unable to process discounts with terms for less than 20 days.**
9. **PROHIBITED INTEREST:** Bidder agrees it shall disclose to the City in writing any financial interest, direct or indirect, in Bidder's business or in this transaction held by any City Council member or any City officer or employee. City reserves the right to refuse any bid if City determines a conflict of interest exists. A conflict of interest may be determined to exist in any instance where the City officer or employee participates in or influences any decision-making process affecting a bid or contract in any way whatsoever.
10. **LOCAL VENDOR PREFERENCE:** For bid evaluation purposes, a 1% preference will be applied to the total bid submitted by vendors located within the City limits of Santa Ana.

(rev. Sept. 2004)

GENERAL TERMS AND CONDITIONS OF THIS BID AND ANY RESULTING CONTRACT

1. **PAYMENT:** Payment by City will be processed within thirty (30) days following receipt of proper invoice evidencing work performed and subject to City accounting procedures. No additional charge will be paid by the City unless expressly included and itemized herein.
2. **DELIVERY:** Time of delivery, as shown herein, must be adhered to. All goods shall be shipped F.O.B. destination designated by the City. Vendor assumes full responsibility for packing, crating, marking, transportation and liability for loss and/or damage. All transportation charges to be prepaid by Vendor.

3. **LATE DELIVERY ASSESSMENT:** The Vendor agrees to pay late-delivery assessment for any delay in delivery (except those beyond its reasonable control) beyond the date agreed to and shown in the purchase order or contract in an amount equal to the expenses incurred by the City due to the delay, including but not limited to expenses such as rental of like equipment to fulfill the need while awaiting late delivery, added cost of manpower or other resources, or other costs as can be shown to have resulted from delaying receipt of the ordered goods or services. The penalty will be deducted from the amount due to the Vendor under the purchase order or contract.
4. **INSPECTION:** City shall be under no obligation to unpack or inspect the products and/or service. The Vendor shall be responsible for the consequences of negligent manufacture and packing, and for the consequences of negligent handling prior to point where City assumes ownership. The expense of subsequent tests due to failure of goods first offered will be charged against the Vendor.
5. **GENERAL GUARANTEE:** The Vendor guarantees that a) Vendor owns all rights, title and interest in the products and services and has the legal authority to sell, license or otherwise transfer the right to use to the City; b) the products and services are free from defects in material and workmanship for a minimum period of one (1) year from the date of acceptance by the City, unless otherwise stated as part of the bid; and c) Vendor shall repair or replace all such defective goods F.O.B. destination
6. **NONDISCRIMINATION:** Vendor agrees that the "Certification of Nondiscrimination by Contractors" attached and executed by Vendor or on file with the City, is specifically made a part of the bid by this reference.
7. **INDEMNIFICATION:** The Vendor guarantees and agrees to indemnify, defend and hold harmless the City against any or all loss, liability damages, demands, claims or costs alleged by third parties arising out of Vendor's performance. This includes defective material and products, faulty work performance, negligent or unlawful acts, and noncompliance with any applicable local, state or federal codes, ordinances, orders or statutes including, but not limited to, the Occupational Safety and Health Act (OSHA) and the California Industrial Safety Act. This guarantee is in addition to and not intended as a limitation on any other warranty, expressed or implied.
8. **TERMINATION:** The City reserves the right to terminate the order or delay delivery or acceptance of any products and/or services ordered resulting from this bid without penalty upon thirty (30) days written notice to the Vendor.
9. **ASSIGNMENT:** Vendor may not assign, transfer, delegate, or subcontract any right, obligation, performance herein without the prior written consent of the City's Purchasing Manager and any such assignment, transfer, delegation or subcontract without the Purchasing Manager's prior written consent shall be considered null and void.
10. **DEFAULT:** In case of default by the Vendor of any of the conditions of this bid or contract resulting from this bid, the Vendor agrees that the City may procure the articles or services from other sources and may deduct from the unpaid balance due the Vendor, or collect against the bond or surety, or may invoice the Vendor for excess costs so paid plus reasonable administrative costs. Prices paid by the City shall be considered the prevailing market price at the time such purchase is made.
11. **LAW AND JURISDICTION:** The validity, performance and construction of this order shall be governed by the laws of the State of California. Both parties further agree that Orange County, California, shall be the venue for any action or proceeding that may be brought or arise out of, in connection with or by reason of this Agreement.
12. **ADDITIONAL TERMS:** No additional term specified in the bid shall be part of the contract unless affirmatively accepted by the City in writing.
13. **BUSINESS LICENSE:** The City requires any person, including but not limited to, an individual, corporation, or sole proprietor who wishes to conduct any business within the City of Santa Ana must secure a City of Santa Ana business license. Procedure to obtain a City of Santa Ana business license is available on the City's web site www.santa-ana.org or call 714-647-5447 for details.

TOTAL QUALITY SERVICE

The City of Santa Ana is committed to the principles of Total Quality Service (TQS) in serving its customers. All aspects of the City's service are affected including our commitment to making **on time payment** for material and services received.

Since vendors, who provide services and/or material to the City are indirectly serving the same customers, it is important for the City to expect vendors to share the same commitment to quality including **price, delivery and product quality, as well as timely response and service quality.**

Therefore, prepare a statement of your "quality commitment" to accompany your bid. The statement should address the following five items in regard to services and/or material provided to the City for your quoted price:

1. **ON-TIME DELIVERY:** a commitment to delivering material & services on or before the promised time.
2. **TIMELY RESPONSE:** a commitment to consistent timely response to all service requests.
3. **QUALITY AS SPECIFIED:** a commitment to provide products and/or service meeting or exceeding the specification at your **quoted price.**
4. **QUALITY CONTROL:** a commitment to use methods or procedures to assure quality control of service, material and invoicing.
5. **CUSTOMER SATISFACTION:** a commitment to resolve customer concerns regarding the quality of service or material supplied.

The quality statement should be included with your bid. **It is required as a prerequisite to making your bid responsive and therefore must be submitted before your bid is evaluated.** To the extent that your statement enhance the quality of service or material provided to the City, your statement will be incorporated in the terms and conditions of the contract.

Please Complete This Self-Rating of Delivery (complete) Performance:					
Circle One:	on time	←	→	late	
Previous Orders:	5	4	3	2	1
Service Response Performance:	5	4	3	2	1
Order for items on this bid:	5	4	3	2	1

Write your statement below or on an enclosed separate sheet.

Signed: _____

Date: _____

CERTIFICATION OF NONDISCRIMINATION BY CONTRACTORS

As suppliers of goods or services to the City Of Santa-Ana, the Firm listed below certifies that it does not discriminate in its employment with regard to race, color, religion, sex or national origin; that it is in compliance with all federal, state and local directives and executive orders regarding nondiscrimination in employment; and that it agrees to demonstrate positively and aggressively the principle of equal opportunity in employment.

WE AGREE SPECIFICALLY:

- 1. To take affirmative steps to hire minority employees within the company.
- 2. To establish or observe employment policies which affirmatively promote opportunities for minority persons at all job levels.
- 3. To communicate this policy to all persons concerned, including all company employees, outside recruiting services, especially those servicing minority communities, and to the minority communities at large.

FIRM _____

TITLE OF PERSON SIGNING _____

SIGNATURE _____ **DATE** _____

Please include any additional information available regarding equal opportunity employment programs now in effect within your company.

GENERAL DESCRIPTION

1. **BID SUBMISSION:** Bids must be submitted to the Purchasing Office in a sealed envelope showing on the outside, the name of the bidder, BID No. 12-013, and date & time of opening. All bids must be signed by an authorized representative of the Offeror.
2. **BID WITHDRAWAL:** Bids may be withdrawn by written request received before the hour set for the opening. After the time, proposals may not be withdrawn by the offeror for a period of ninety (90) days from the date of the opening up to when a contract is awarded.
3. **LATE BIDS:** It is the responsibility of the offeror to see that any bid submitted shall have sufficient time to be received by the Purchasing Office prior to proposal due date and time. **Late bids will be returned to the Offeror unopened.**
4. **OFFEROR AGREEMENT:** Submission of a signed bid will be interpreted to mean that offeror has hereby agreed to all the terms and conditions set forth in all of the sheets which make up this Invitation For Bid.
5. **CONTRACT:** Offeror's signed bid and written acceptance by the City shall constitute a contract.
6. **ACCEPTANCE OF THE OFFER:** Acceptance of the offer shall be limited to the terms herein unless expressly agreed in writing by the City.
7. **SELL OR ASSIGN:** The successful offeror shall not have the right to sell, assign, or transfer any obligations resulting from this proposal without the specific written consent of the City.
8. **CANCELLATION:** This agreement may be canceled at any time WITH CAUSE within ten (10) days written notice to the supplier. Cancellation for cause shall be at the discretion of the City and shall be, but is not limited to, failure to supply the product and equipment specified within the time specified or within the terms, conditions and provisions of this proposal.
9. **RECEIVING TIME:** The receiving time in the Purchasing Office will be the governing time for acceptability of bids. Telegraphics, telephonic and facsimile proposals will not be accepted.
10. **COMPLIANCE WITH LAWS:** All bids shall comply with current federal, state, and other laws relative thereto. Offeror further agrees that the goods proposed comply with all applicable Federal and State Occupational Safety and Health laws, standards for regulations, and that Seller will indemnify and hold the Buyer harmless for any failure to so conform.
11. **LAWS GOVERNING CONTRACT:** This contract shall be in accordance with the laws of the state of CALIFORNIA. Parties further stipulated that this contract was entered into in the state of CALIFORNIA and the state of CALIFORNIA is the only appropriate forum for any litigation as a result of breach hereof or any questions risen here from.
12. **ATTORNEY'S FEES:** In the event a suit or action is instituted in connection with any controversy arising out of this contract, the prevailing party shall be entitled to receive, in addition to its costs, such sum as the court may judge reasonable as to attorney's fees and costs.
13. **FORCE MAJEURE (ACTS OF GOD):** If execution of this contract shall be delayed or suspended and if such failure arises out of causes beyond the control of and without fault or negligence of the Offeror, the Offeror shall notify the City, in writing, within twenty-four (24) hours, after the delay.
14. **Submit one original offer and one (1) copy of offer.**

TERMS AND CONDITIONS

- 1. RIGHTS RESERVED** – The City reserves the right to accept or reject any and all bids and to waive any informality in any bid.
- 2. TOTAL QUALITY SERVICE and CERTIFICATION OF NONDISCRIMINATION BY CONTRACTS** – The City firmly believes in the “Total Quality Service” and “Certification of Nondiscrimination by Contracts”. Failure to comply with the statements and submit signed documents with your bid may result in termination of the contract.
- 3. BILLING** - Invoices are mailed to City of Santa Ana, Purchasing Div. M-16, P.O. Box 1988, Santa Ana, CA 92702 Invoices must reference Purchase Order number issued for each order. Invoices are processed for payment after review and approval by authorizing department.
- 4. OFFEROR’S REFERENCES:** Each proposal must be returned with an Offeror’s Reference sheet, completed in full. The City reserves the right to conduct reference checks. Failure to provide a minimum of three (3) required reference information will eliminate your agency from consideration.
- 5. CALIFORNIA SALES TAX:** The City of Santa Ana pays full sales tax at the Orange County rate of 7.75% California Sales Tax (if applicable) must be shown separately on the Bid Form.
- 6. F.O.B. POINT & SHIPPING CHARGE:** All prices shall be quoted F.O.B. Destination Santa Ana, California. All shipping, handling and freight charges shall be included on proposal form. No separately stated charges will be considered.
- 7. PAYMENT DISCOUNTS:** Payment discounts of 20 days or more will be considered in award of bid.

ADDITIONAL TERMS AND CONDITIONS

OFFERER’S REFERENCES:

A list of a minimum of three (3) references, including company name and address, contact name, and phone number, from customers receiving similar services as required in this Invitation for Bid must be submitted with each bid using the supplied form or on separate sheet. References from governmental entities are preferred but not required. These references shall be used in the evaluation of this bid to determine award.

TOTAL QUALITY SERVICE AND CERTIFICATION OF NONDISCRIMINATION BY CONTRACTORS: The City firmly believes in “TOTAL QUALITY SERVICE” and “CERTIFICATION OF NONDISCRIMINATION BY CONTRACTORS”. Failure to comply with both statements submitted with your bid may result in termination of the contract.

INSURANCE REQUIREMENTS:

As a condition of this contract, the contractor shall obtain and maintain throughout the term of the contract insurance as described below. A certificate of insurance, naming the City of Santa Ana as an additional insured, shall be provided to the Buyer before award. Certificate is not required with bid offer. Certificate required when contract awarded.

- General Liability - \$1,000,000 each occurrence
- Workers Compensation - Within limits required by the State of California
- Automobile Insurance - \$1,000,000 combined single limit
- Liability Insurance naming the City of Santa Ana, its officers, agents and employees as additional insured on a separate Additional Insured Endorsement sheet.
- 30-day guarantee notice of cancellation.

BUSINESS LICENSE: The City requires a business license be secured by all vendors who conduct business within the City of Santa Ana. As part of the award of a contract on Bid 11-069, proof of your current business license in the form of a copy of the Santa Ana business license must be provided. Or proof that you have applied for a 2011 business license provided within 10 days from receiving a Purchase Order contract. Upon receiving the actual business license, a copy will be provided to the Purchasing Department. A current business license must be maintained for the entire term of the contract. Failure to do so will result in immediate cancellation of the City's contract.

SCOPE

A successful contractor shall provide all labor, materials, and equipment necessary to complete the Corbin Center re-roofing project as specified here in. Address for the Corbin Center is 2215 W. McFadden Avenue, Santa Ana CA 92704. Offers presented must include all cost stated as a **NOT TO EXCEED TOTAL COST.**

SELECTED MANUFACTURER:

The City's Building Maintenance Department sets City standards for equipments, including motors, HVAC units and roof materials to maintain consistent quality, uniformity on repairs with in-house technicians and best value based on total cost of ownership. The BASF FE 348 2.5 Series spray polyurethane foam roofing material and UNISIL High Solids Silicone Waterproofing, with ceramic granules have proven to meet the City's requirements.

BRAND OR TRADE NAMES AS A DESCRIPTION:

Certain specifications, brand names and the like are set forth for the purpose of setting a standard and are not intended to preclude any vendor from bidding who can substantially meet these specifications. Vendors may propose materials and roofing techniques equal to those specified herein; each deviation must be set forth in detail.

QUALIFICATIONS:

The bidder, at time of bid submittal and throughout the term of the project, shall possess the correct occupational and/or profession licenses necessary to carry out and perform the work required pursuant to all applicable Federal, State and Local laws, statues, ordinances, rules and regulations.

The contractor shall have a least five (5) years experience performing work of comparable size and scope. A list of a minimum of three (3) references, including company name and address, contact name, and phone number, from commercial customers receiving similar services as required in this Invitation For Bid, must be submitted with each bid. References from governmental entities are preferred but not required. These references shall be used in the evaluation of this bid to determine award.

LICENSES AND PERMITS:

- A. Business License: Each prime contract and sub contractor shall obtain and pay for a Santa Ana Business License. Detailed information concerning business licenses may be obtained from the Finance and Management Services Agency at 714-647-5447 or at the City's web site at [www:santa-ana.org](http://www.santa-ana.org).
- B. Disposal Permit: In accordance with the procedures of the Orange County GSA, the cost for the disposal of all materials at County landfill sites shall be borne by the Contractor.
- C. Building Permits: For projects involving building or structural construction, the Prime Contractors shall obtain the necessary building permits from the City of Santa Ana Planning & Building Agency. There will be no fee for these permits.
- D. All permits and fees required by all other Agencies having jurisdiction over any part of the work shall be obtained and paid for by the Contractor, unless otherwise noted on the Plans or in the Special Provisions.

WORKING HOURS:

Unless otherwise instructed, all installation and associated work shall be performed on a Friday, Saturday and Sunday schedule, between 8 a.m. to 5 p.m., with approval by Mario Ghizzi, Facilities Maintenance Superintendent.

SPECIFICATIONS FOR SPRAYED POLYURETHANE FOAM ROOFING

PART 1 – GENERAL

- A. This roofing system consists of a layer of sprayed in-place urethane foam roof insulation with two coats of silicone protective coating (UNISIL High Solids Silicone Waterproofing in the color white) and surfaced with white ceramic granules.
- B. Roofing system to conform to requirements of a Class A system under UL 790.

1.01 SCOPE OF WORK

The contractor shall furnish all labor, materials, tools and equipment necessary for the application of a polyurethane foam roofing system, including accessory items, subject to the general provisions of the contract. Preparation of substrate and necessary repair or alterations to substrate, flashing, and penetrations shall be incidental to this section.

1.02 QUALITY CONTROL

Inspections: The contractor is required to have the polyurethane foam and protective coating manufacturers provide qualified representatives to monitor and inspect the installation of their product. Third party inspection of the installation is required and shall be provided at no additional cost to the City. A list of SPFA inspector members is available at http://www.sprayfoam.org/index.php?page_id=4535.

1.03 SUBMITTALS

- A. The contractor shall provide manufacturer's published data sheets or letter of certification that their products comply with the materials specified. This shall include primers, polyurethane foam and protective coatings.
- B. Shop drawings on sheet metal, accessories, or other fabricated items.
- C. Manufacturer's application or installation instructions.
- D. Contractor/applicator certification from polyurethane foam supplier and/or protective coatings manufacturers and evidence of contractor/applicator qualification and experience. See Section 1.03.
- E. A specimen copy of the applicable warranty for the project. See Section 1.08.
- F. Approval and information guides for applicable local or national codes and/or insurance acceptability, if required.
- G. Safety and handling instructions for storage, handling and use of the materials to include appropriate Materials Safety Data Sheets (MSDS).
- H. Field Quality Control Procedures to be utilized by the contractor/applicator to ensure proper preparation and installation of polyurethane foam and protective coatings, detail work and follow-up inspection.
- I. SPFA sprayed polyurethane foam surface visual guide.

1.04 MATERIALS, DELIVERY, AND STORAGE

- A. Materials shall be delivered in the manufacturers original, tightly sealed containers or unopened packages, all clearly labeled with the manufacturer's name, product identification, safety information, and batch or lot numbers where appropriate. Where materials are covered by a referenced specification, the labels shall bear the specification number, type, and class, as applicable.
- B. Containers shall be stored out of the weather and direct sunshine where the temperature is within the limits specified by the manufacturer.
- C. All materials shall be stored in compliance with local fire and safety requirements.

1.05 ENVIRONMENTAL CONDITIONS

- A. The polyurethane foam applications shall not proceed during period of inclement weather. Do not apply the polyurethane foam below the temperature and/or above humidity specified by the manufacturer for ambient air and substrate.

- B. Do not apply protective coatings when there is ice, frost, surface moisture or visible dampness present on the surface to be coated. Prior to applying the coatings, check the polyurethane foam to insure that the surface is dry. Apply protective coatings in accordance with the coatings manufacturer's application instructions.
- C. Wind barriers may be used if wind conditions could affect the quality of the polyurethane foam or protective coating installation.

1.06 SEQUENCING AND SCHEDULING

There shall not be any other trades-people working on the roof when the spray polyurethane foam and coating are being installed.

1.07 WARRANTY

The contractor shall provide a **MANUFACTURER'S FULL SYSTEM WARRANTY** for a minimum of ten (10) years with an option for a fifteen (15) year full system warranty.

1.08 SAFETY REQUIREMENTS

- A. See CPI Bulletin AX-205, "Working with MDI and Polymeric MDI: What You Should Know."
- B. Refer to appropriate Materials Safety Data Sheets (MSDS) for additional safety information.
- C. Before starting to apply spray polyurethane foam or coating, any potential sources of air entry into the building must be sealed off. These units and any other potential sources of air entry into the building must be sealed.

PART 2 – PRODUCTS

2.01 POLYURETHANE FOAM – BASF FE 348 2.5 Series roofing material

- A. The polyurethane foam to be applied shall be a two-component system made by combining an isocyanate (A) component with a polyol (B) component and shall possess the following physical characteristics:

Note attached Exhibit 1 for BASF TECHNICAL PRODUCT DATA 4 sheets.

*** This standard is used solely to measure and describe properties of products in response to heat and flame under controlled laboratory conditions. This numerical flame spread rating is not intended to reflect hazards presented by this or any other material under actual fire conditions.*

- B. Polyurethane Foam Primers: Primers used shall be as recommended by the manufacturer of the spray foam materials specified.

- C. Fire Safety Requirements: See CPI Bulletin AX-230, "Fire Safety Guidelines for Use of Rigid Polyurethane and Polyisocyanate Foam Insulation in Building Construction."

2.02 PROTECTIVE COATING

- A. The Elastomeric Coating System shall be United Coatings UNISIL HS for approved equal.
 - 1. Silicones (See ASTM D6694 Standard Specification for Liquid-Applied Silicone Coating Used in Spray Polyurethane Foam Roofing)
- B. Physical Properties: The Elastomeric Coating System shall possess the following physical characteristics:

Note attached Exhibit 2 for UNISIL HS - High Solids Silicone Waterproofing.

2.03 ACCESSORIES AND MISCELLANEOUS MATERIALS

- A. Flashings and waterproof coverings for expansion joints shall be compatible with specified polyurethane foam and elastomeric coating system and shall be as recommended by the manufacturers of the systems specified.
- B. Miscellaneous materials such as adhesives, elastomeric caulking compound, metal, vents and drains shall be a composite part of the roof system and shall be those recommended by the systems manufacturer.
- C. Granules: When used, shall be of the size and type and applied in the topcoat as recommended by the coating manufacturer.
- D. Board stock: If required over metal decks, fasten to achieve necessary wind uplift requirements.

PART 3 – EXECUTION

3.01 GENERAL

- A. Guidelines as outlined by the manufacturer issuing the warranty shall be the final specification authority.
- B. Protect surfaces near roofing operations from spray or roofing materials.

3.02 SURFACE PREPARATION AND PRIMING

- A. Built-up Roof (Retrofit)
 - 1. All loose gravel, dust and residue shall be removed using power vacuum equipment, power sweeper, air blowing, or other suitable means.

2. The roof shall be thoroughly inspected or tested to determine if moisture is present within the roof assembly. Saturated insulation must be removed and replaced with compatible materials.
3. The existing roof shall be thoroughly inspected for adhesion between felts, insulation, and deck. Areas of poor adhesion should be fastened. Blisters, buckles, and fish mouths shall be cut out and/or fastened.
4. All soft mastic or other materials that impeded polyurethane adhesion shall be removed or covered with a mechanically fastened recover board.
5. Remove or refasten all loose base flashing, counter flashing and gravel stops as required.
6. Lightning rods shall be masked prior to foaming. Lightening rod cables shall not be embedded in the polyurethane foam and should be removed prior to foaming. Electrical and mechanical conduits should be relocated or raised above the finished roof surface. Lightening protection equipment and electrical work must be performed by qualified personnel.

3.03 POLYURETHANE FOAM APPLICATION

A. Inspection

1. Prior to application of the foam, the surface shall be inspected to ensure that conditions required by Section 3.02 have been met.
2. Substrate shall have sufficient slope to eliminate excessive ponding water. Ponding is defined as "The accumulation of water in low-lying areas that exceeds the manufacturer's specification and/or contract documents." If the substrate does not have sufficient slope, then the ponding water must be eliminated by building in slope by the application of polyurethane foam, channeling the polyurethane foam or by the proper placement of drains, or a combination thereof.
3. The polyurethane foam application shall not proceed during periods of inclement weather. The applicator shall not apply the polyurethane foam below the temperature and/or humidity specified by the manufacturer for ambient air and substrate. Wind barriers may be used if wind conditions could affect the quality of installation.

B. Application

1. The spray polyurethane foam shall be applied in accordance with the manufacturer's specifications and instructions.
2. Areas to be built-up to remove ponding water are to be filled in with spray polyurethane foam before the specified thickness of polyurethane foam is applied to the entire roof surface.
3. The spray polyurethane must be applied in a minimal pass thickness of ½ inch.

4. Spray polyurethane foam thickness shall be a minimum of two (2) inches. The polyurethane foam shall be applied uniformly over the entire surface with a tolerance of plus ¼" per inch of thickness minus 0", except where variations are required to ensure proper drainage or to complete a feathered edge.
5. The spray polyurethane foam shall be uniformly terminated a minimum of four (4) inches above the roofline at all penetrations (except drains, parapet walls, or building junctions). Foamed in place cants shall be smooth and uniform to allow positive drainage.
6. When detailing skylights or high walls, it is particularly important not to cover weep holes with SPF or coating.
7. The full thickness of polyurethane foam in any area shall be completed prior to the end of each day. If due to weather conditions more than 24 hour elapse between polyurethane foam and coating application, the polyurethane foam shall be inspected for UV degradation, oxidation or contamination. If any of the above conditions exist, the surface shall be prepared in conformity with the recommendations of the manufacturer issued the warranty.
8. The dry mill thickness must comply to the following ratings to meet FULL SYSTEM WARRANTY. If the dry mill thickness is less than stated minimum, contractor responsible to bring the dry mill up to stated minimums.
 - a. Coating warranty for 10 years has a minimum 35 dry mill.
 - b. Coating warranty for 15 years has a minimum 30 dry mill.

C. Surface Finish

1. The final sprayed polyurethane foam surface shall be "smooth, orange peel, coarse orange peel, or verge of popcorn." Polyurethane foam surfaces termed "popcorn" or "treebark" are not acceptable. These areas shall be removed and re-foamed to an acceptable surface. (See surface texture photos)
2. Any damage or defects to the polyurethane foam surface shall be repaired prior to the protective coating application.
3. The polyurethane foam surface shall be free from moisture, frost, dust, debris, oils, tars, grease or other materials that will impair adhesion of the protective coating.

3.04 PROTECTIVE COATING APPLICATION

A. Inspection

1. Prior to the application of the protective coating, the polyurethane foam shall be inspected for suitability of base coat application as per Section 3.03. The polyurethane foam shall be clean, dry, and sound.

B. Application

1. Base Coat

- a. The base coat shall be applied the same day as the polyurethane foam application when possible. In no case shall less than two hours elapse between application of the polyurethane foam and application of the base coat. If more than 24 hours elapse prior to the application of base coat, the polyurethane foam shall be inspected for UV degradation.
- b. The polyurethane foam shall be free of dust, dirt, contaminations and moisture before application of the base coat.
- c. The base coat shall be applied at a uniform thickness with the rate of application being governed by the polyurethane foam surface texture. Coatings shall be applied at such a rate as to give the minimum dry film thickness specified by the protective coating manufacturer.
- d. The coating shall be allowed to cure and be inspected for pinholes, thinly coating areas, uncured areas or other defects. Any defects should be repaired prior to subsequent applications. The base coat shall be free of dirt, dust, water, or other contaminants before application of the topcoat.
- e. The coating application shall not proceed during periods of inclement weather. The applicator shall not apply the protective coating below the temperature and/or above the humidity specified by the manufacturer for ambient air and substrate. Wind barriers may be used if wind conditions could affect the quality of installation.

2. Topcoat and/or Subsequent Coat

- a. Application – Subsequent coating should be applied in a timely manner to ensure proper adhesion between coats. Surface texture of polyurethane foam will affect dry film thickness—additional material may be required in areas of coarse foam profile.
- b. Inspection – The cured dry film thickness of the finished multiple coat application shall be checked by taking slit samples and examining under magnification. Areas that are found to have less than the thickness specified shall require additional coating.

3.05 GRANULE APPLICATION

Granules, when specified, should be embedded in the topcoat. Apply granules into the final layer of the coating while it is still wet. White granules should be applied at a rate and method based on the manufacturer's recommendations.

3.06 WALKWAYS

Walkways may be installed for heavy traffic areas and around frequently serviced roof top units. Breathable walk pads, "yellow spaghetti or equal", should be recommended by the coating manufacturer.

3.07 GUTTERS

Gutters do not need to be replaced but gutter metal edges must be replaced by end of project.

3.08 AIR CONDITIONING METAL COVERS

The four (4) air conditioning metal covers on roof, underneath the A/C units, must be replaced by end of project.

3.09 ROOF CORNER FLASHINGS

Flashing must be replaced by end of project.

3.10 SKYLIGHTS

Skylights to remain but remove and seal all around the skylights with roofing material specified herein.

3.11 PARAPETS

All existing parapets to be prepared for coating material and sprayed no less than 50% of their respective height.

UNISIL HS:

High Solids Silicone Waterproofing manufacturer's specification sheets attached as Exhibit 2.

INSPECTION WORK:

All work for the Corbin Center re-roofing project shall be inspected by either the City Inspector and/or Facilities Maintenance Superintendent for acceptance.

SAFETY:

The contractor, its employees and subcontractors shall perform all work activities in a safe work like manner respecting and following all applicable safety standards, rules, regulations, laws and codes including Lock Out Tag procedures.

MAINTAINING REQUIRED INSURANCE FOR FULL TERM OF PROJECT:

If the contractor allows their required insurance coverage to expire or their insurance is cancelled at any time during the project, the vendor shall provide the BUYER with an updated, valid, certificate of liability insurance. Lack of current insurance coverage will hold up payments until adequate proof of insurance is provided.

WORK STANDARDS:

All work performed by Contractor shall be to a professional standard, complying with the requirements of the applicable editions of the Standard Specification for Public Works Constructions, and State and Local building codes.

EQUIPMENT:

Contractor shall own and have in good repair all equipment necessary to perform the described services and the equipment necessary to complete related tasks.

PREVAILING WAGE CLASSIFICATION:

The City Charter defines Public Works construction as a project for the erection or improvement of public buildings, streets, drains, sewers, parks or playgrounds with labor at prevailing wage rate. Maintenance and repair of public buildings shall not be considered a public work construction and will not require prevailing wage rates. **The Corbin Center re-roofing projects outlined under IFB 12-013 is categorized as maintenance and repair of public buildings with no prevailing wage requirement.**

CLEAN UP:

The Contractor shall be responsible for removing all debris from the site and cleaning affected areas daily after performing work. Contractors shall keep the premises free of debris and unusable materials resulting from their work at all times, and upon completion, leave all affected areas as they were prior to beginning work.

PROTECTION OF PROPERTY:

1. The contractor shall perform work in such a manner that does not damage property. In the event damage occurs to property by reason of any repairs or installations performed under this contract, the contractors shall replace, or repair the same at no cost to the City. If damage caused by the contractors must be repaired or replaced by the City, the cost of such work shall be deducted from any outstanding balance due the contractor.

2. Vehicles in parking lot around the Corbin center – Vehicles in parking lot must be protected during the re-roofing project. City will make every effort to restrict parking in the Corbin Center parking lot during the project period. Any vehicles in the parking lot must be draped and covered with plastic for full protection during the entire project.

UNSATISFACTORY WORK:

In the event the work performance of the contractor is unsatisfactory, the contractor shall be notified and shall have seven (7) calendar days to correct the work at no charge to the City.

ASKING QUESTIONS:

Please direct any questions or concerns on bid 12-013 specifications, Full System Warranty, as well as the BASF polyurethane foam roofing and UNISEL HS United Coatings silicone coating with a call to Buyer Katie Montgomery, 714-647-5466, or e-mail to kmontgomery@santa-ana.com.

CONTRACTOR'S QUALIFICATIONS

NAME OF FIRM: _____

VENDOR ADDRESS: _____

PRIMARY CONTACT: _____

PHONE NUMBER: _____ FAX NUMBER: _____

E-MAIL ADDRESS: _____

INVOICE PROCESSING LOCATION: _____

CONTACT NAME: _____

PHONE NUMBER: _____ FAX NUMBER: _____

QUESTIONNAIRE: May submit on separate sheets for complete answers

1. Number of years your firm has been in the industry? _____

2. General summary of your firm's organization, ownership and services: _____

3. Provide information demonstrating the financial stability of your firm: _____

4. Provide estimated timeline for start of re-roofing project and completion. Subject to approval by City. _____

Return this sheet with your bid.

PRICING SHEET – inclusive of all requirements per specification.

PROJECT: Corbin Center Re-roofing project

	10-yr MFG FULL SYSTEM WARRANTY	15-yr MFG FULL SYSTEM WARRANTY
Supplies and materials for this project	\$ _____	\$ _____
Sales tax at 7.75% - Orange County rate	\$ _____	\$ _____
Labor for this project	\$ _____	\$ _____
Warranty expense if separate fee	\$ _____	\$ _____
Material handling & delivery cost if applicable	\$ _____	\$ _____
TOTAL COST FOR PROJECT	\$ _____	\$ _____

** report on Page 1 of IFB 12-013

Offer must stand as the total cost of the re-roofing project. No additional cost approved at time of invoicing unless outlined and included in this bid offer. OFFER STANDS AS NOT TO EXCEED dollar quote.

Complete the commitment statement: I (name) _____ acknowledge full compliant to the manufacture, brands and stock numbers of the specified products in the Corbin Center re-roofing project. Any deviation to specification so noted in provided documentation.
Company _____ Date _____

Foam Roof Material _____
High Solids Silicone Coating _____

The contractor shall provide a manufacturer’s FULL SYSTEM warranty for a minimum of ten (10) years and fifteen (15) years as priced (sample of warranty included in offer).
Documentation provided _____ date.

COMPANY NAME _____ NAME _____
DATE _____ PHONE NUMBER _____

Submit one original offer and one (1) copy of offer.

**CORBIN CENTER RE-ROOFING
CONTRACTOR'S REFERENCES**

THIS SHEET MUST BE COMPLETED IN FULL AND RETURNED WITH OFFEROR'S PROPOSAL.

List and describe fully the last three contracts performed by your firm, which demonstrate your ability to provide the supplies, equipment, or services included with the scope of the proposal specifications. Attach additional pages if required. The City reserves the right to contact each of the references listed for additional information regarding your firm's qualifications.

Reference No. 1.

Customer Name _____ Contact Individual: _____

Address: _____ Phone Number: _____

_____ Facsimile Number: _____

Contract Amount: _____ Year : _____

Description of supplies, equipment, or services provided:

Reference No. 2.

Customer Name _____ Contact Individual: _____

Address: _____ Phone Number: _____

_____ Facsimile Number: _____

Contract Amount: _____ Year : _____

Description of supplies, equipment, or services provided:

Reference No. 3.

Customer Name _____ Contact Individual: _____

Address: _____ Phone Number: _____

_____ Facsimile Number: _____

Contract Amount: _____ Year : _____

Description of supplies, equipment, or services provided:



INVITATION FOR BID CITY OF SANTA ANA

The address label provided can be affixed to your response envelope to ensure your bid is correctly routed.

IMPORTANT:

1. The label must be attached with clear tape on the sides and top ONLY.
2. The label must be attached at least $\frac{3}{4}$ " from the bottom of the envelope.
3. Use a standard business size #10 envelope or larger envelope if needed.

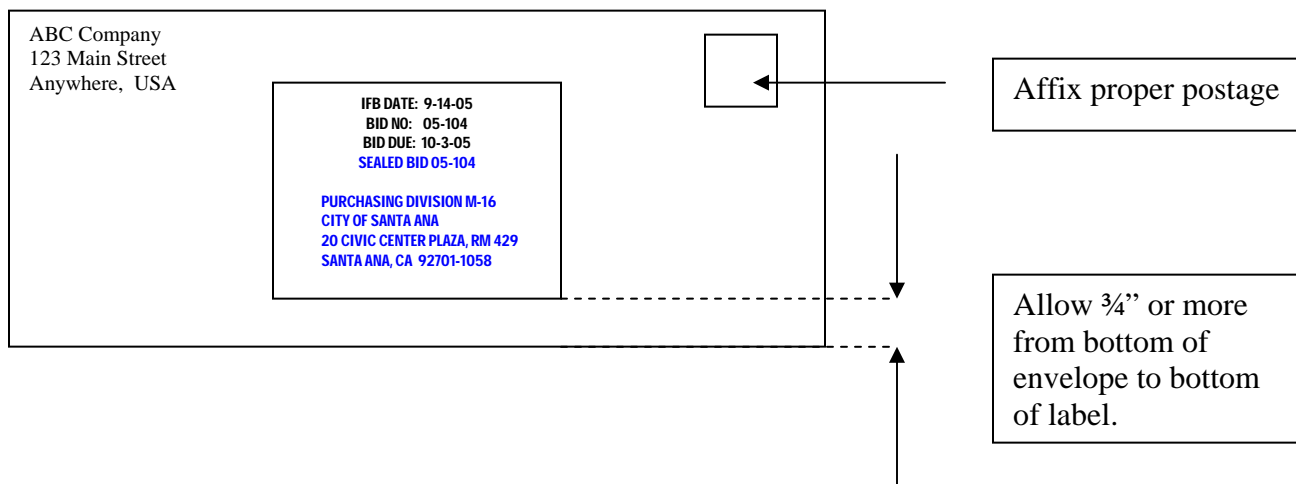

BID NUMBER:
12-013
BID DUE: **(M)**
2-06-12 2:00 PM

“NO BID” NOTIFICATION
CORBIN CENTER RE-ROOFING

If you do not intend to submit a bid at this time, please complete the following and return this page only in the envelope provided.

- We do not offer this commodity / service.
- Other commitments preclude our participation at this time.
- The scope of work is beyond our current capacity.
- Bid requirement too small for our company.
- Cannot meet delivery / completion requirements.
- Prior experience with City of Santa Ana contracts was unprofitable or otherwise unsatisfactory. (Please explain in additional comments section)
- Unable to bid competitively.
- Bonding / Insurance requirements are prohibitive. (Please explain in additional comments section)
- Insufficient time allowed to prepare and respond to bid request.
- The specifications are either unclear or too restrictive. (Please explain in additional comments section)
- Profit margin on municipal bids too low.
- Remove our name from the City’s List of Bidders for this commodity.

Additional comments: _____

Company Name _____

Mailing Address _____

Authorized Name & Title _____

Please print and sign name

Phone Number _____ Fax Number _____



CORBIN CENTER at 2215 W. McFadden Avenue, Santa Ana CA 92704

REVISIONS	BY

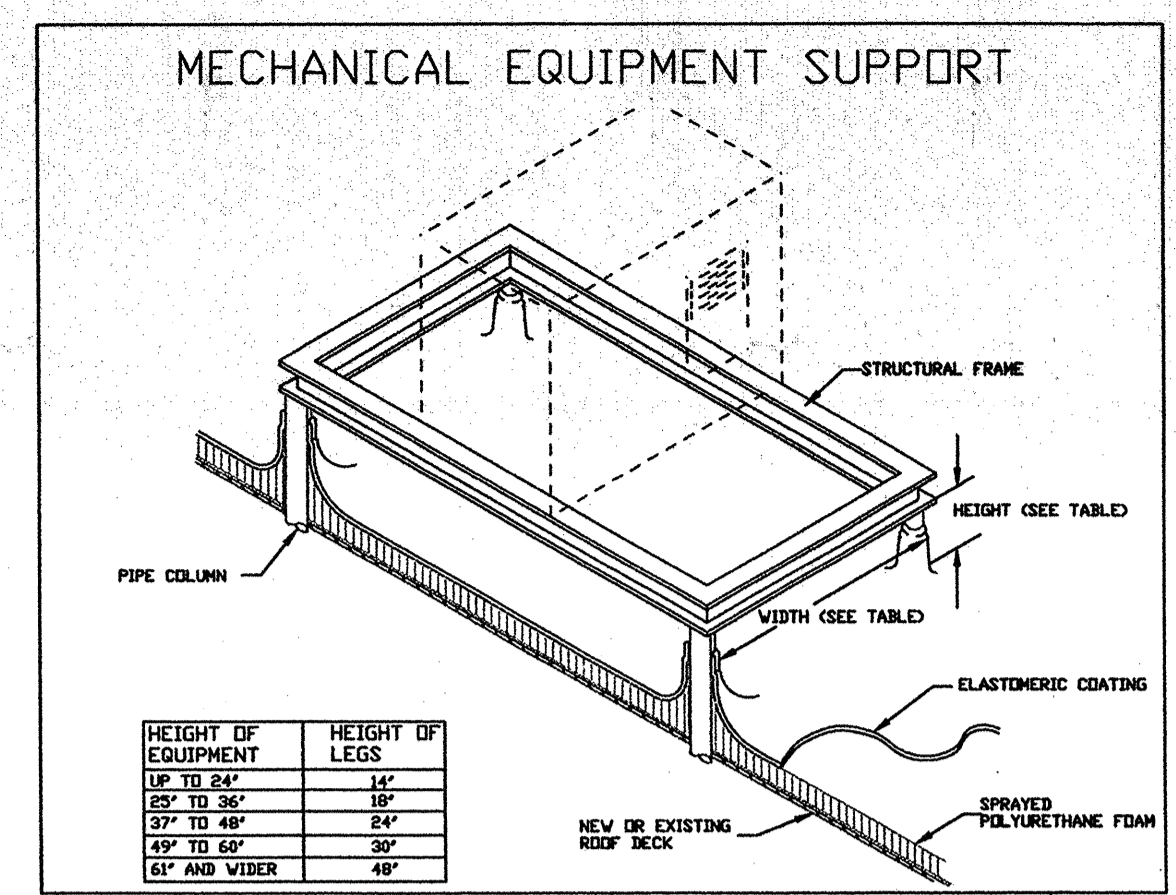

MECH. EQUIPMT SUPPORT

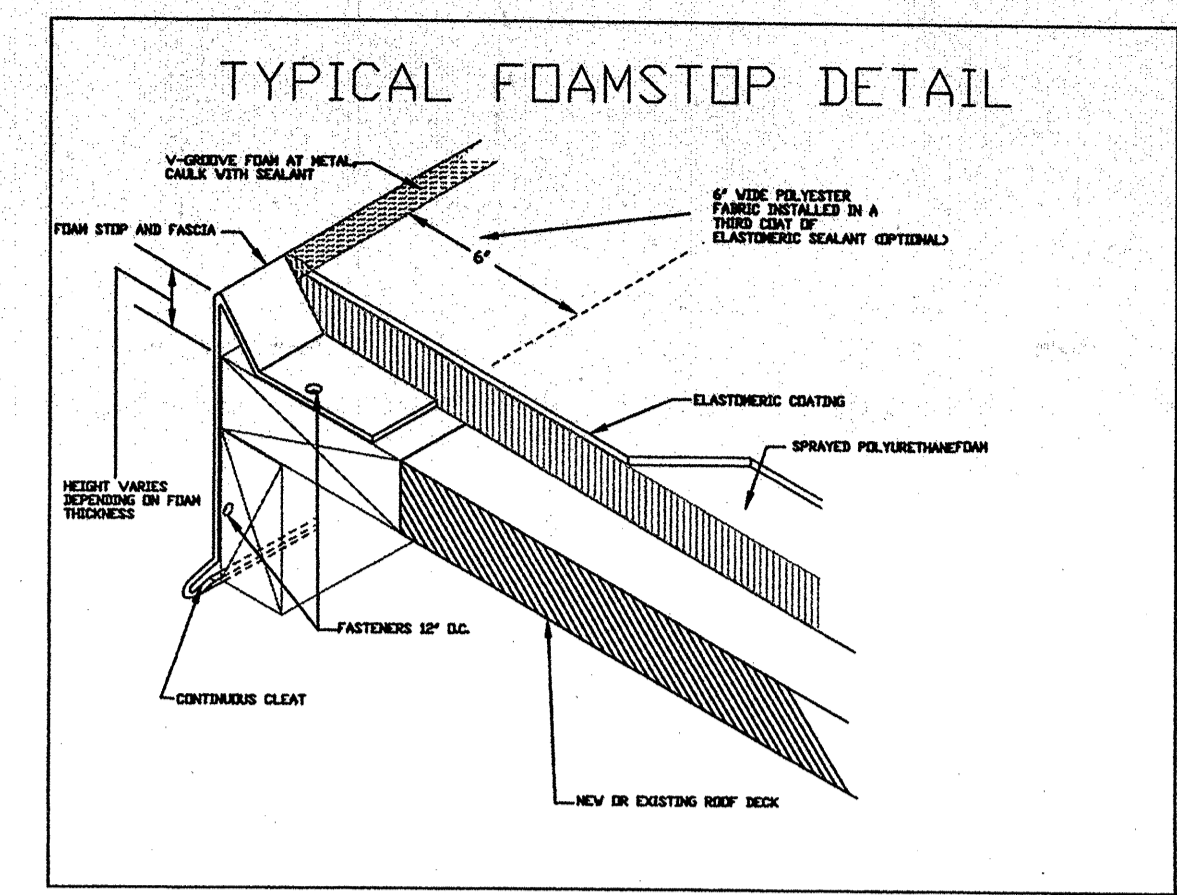

TYPICAL FOAMSTOP DETAIL

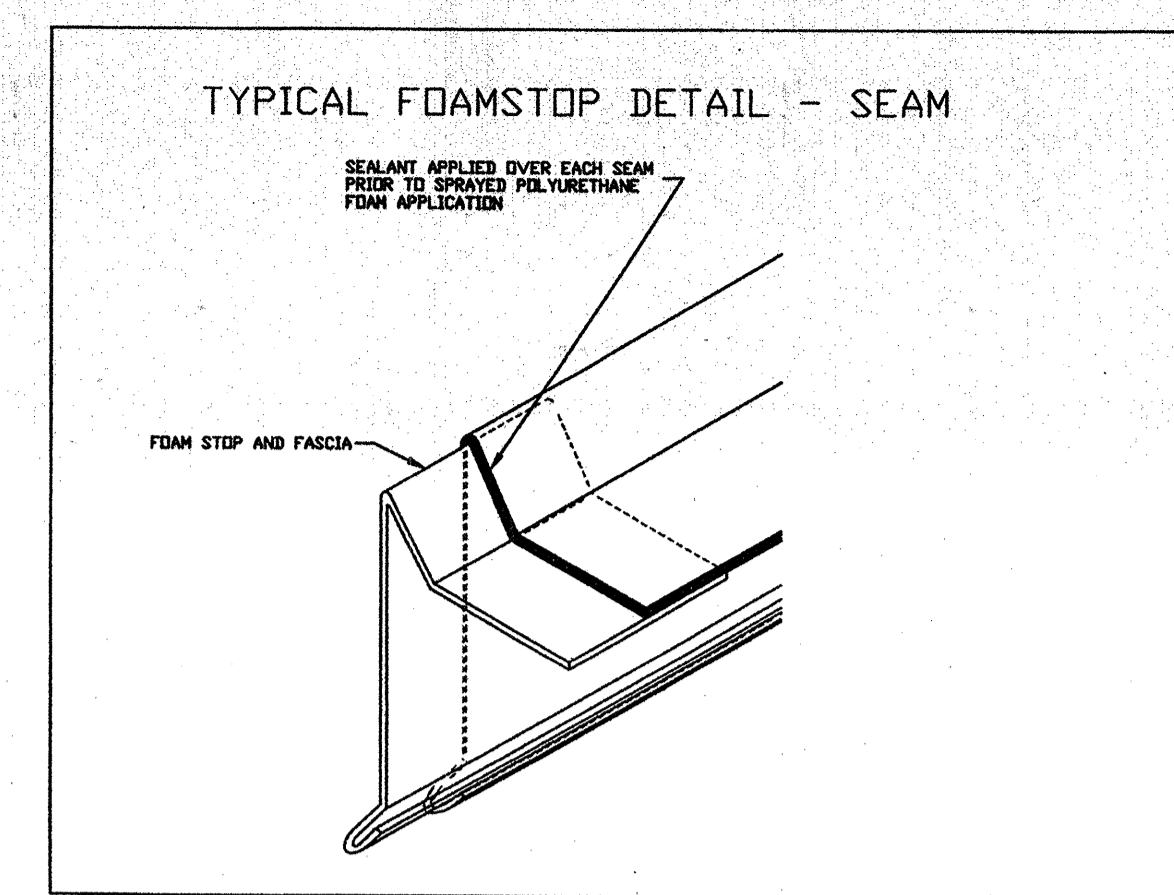

TYPICAL FOAMSTOP SEAM

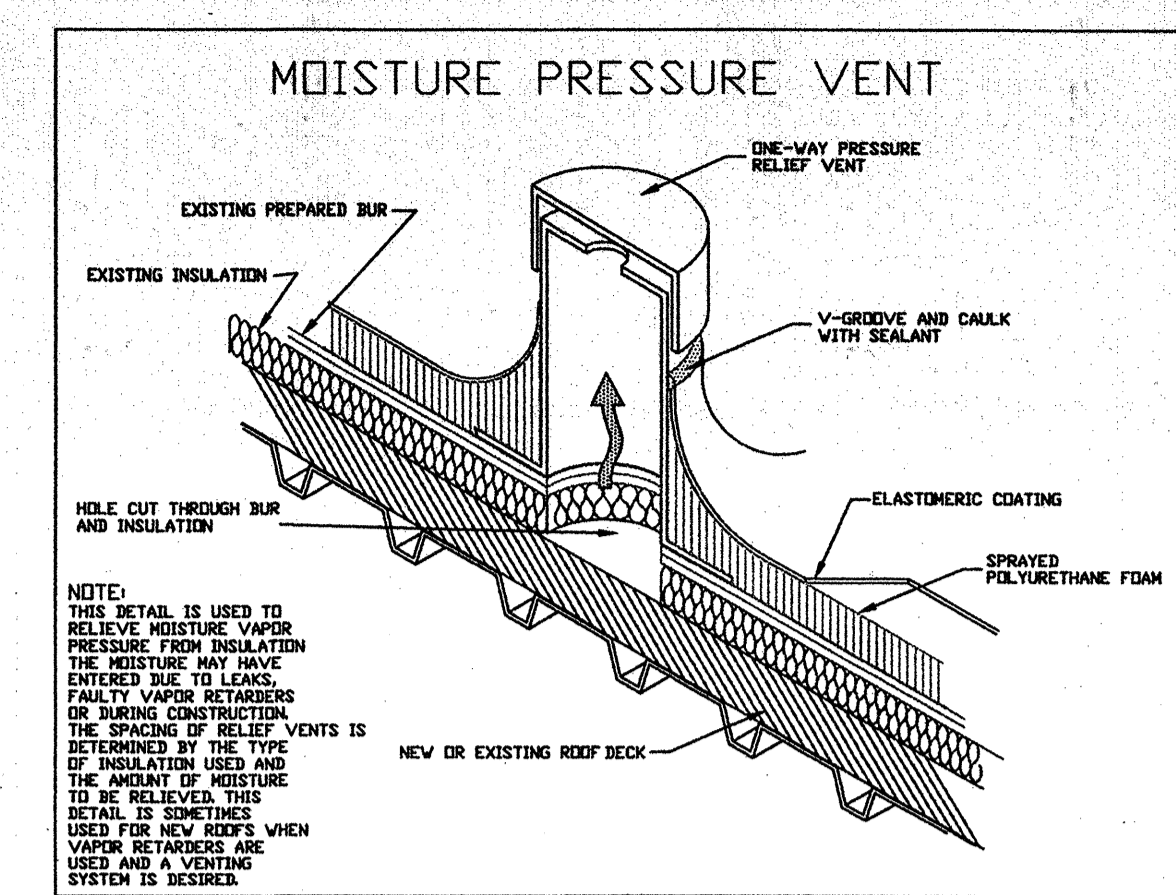

MOISTURE PRESSURE VENT

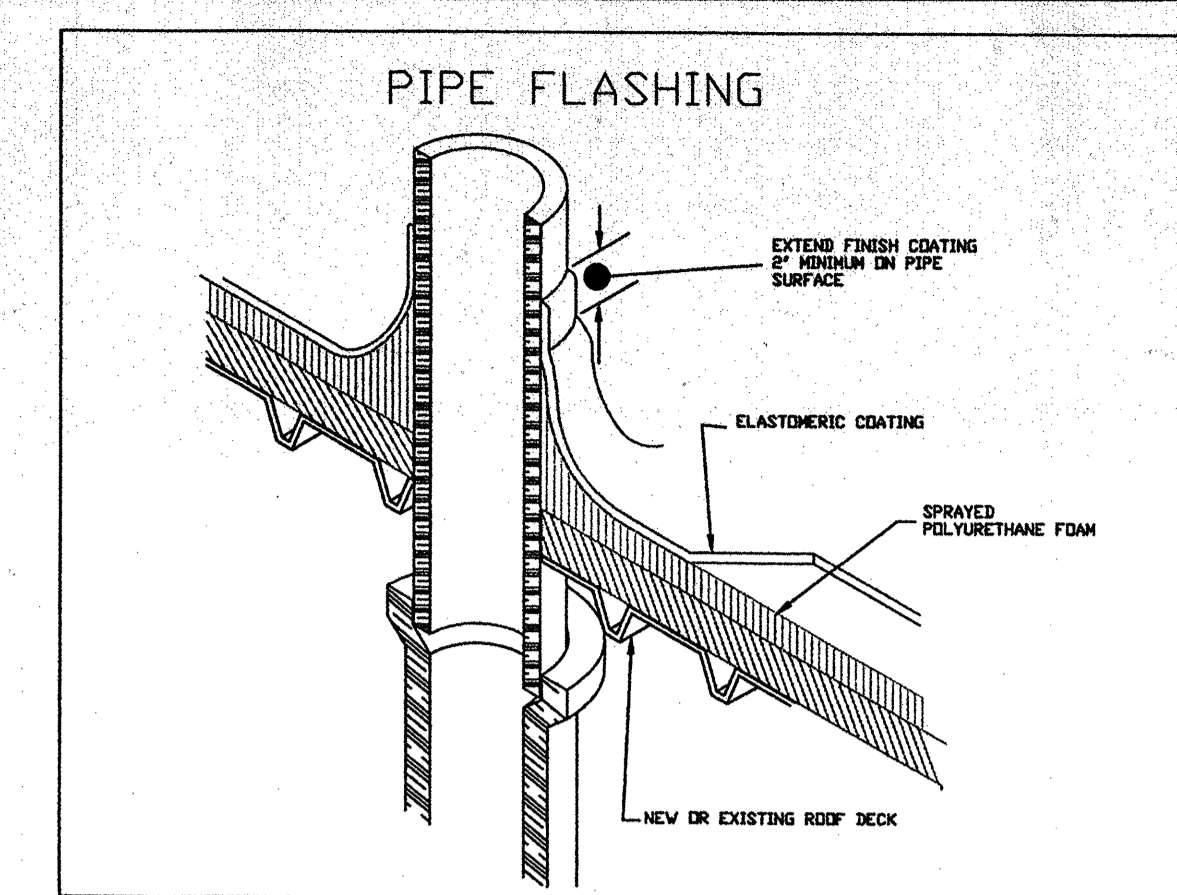

PIPE FLASHING

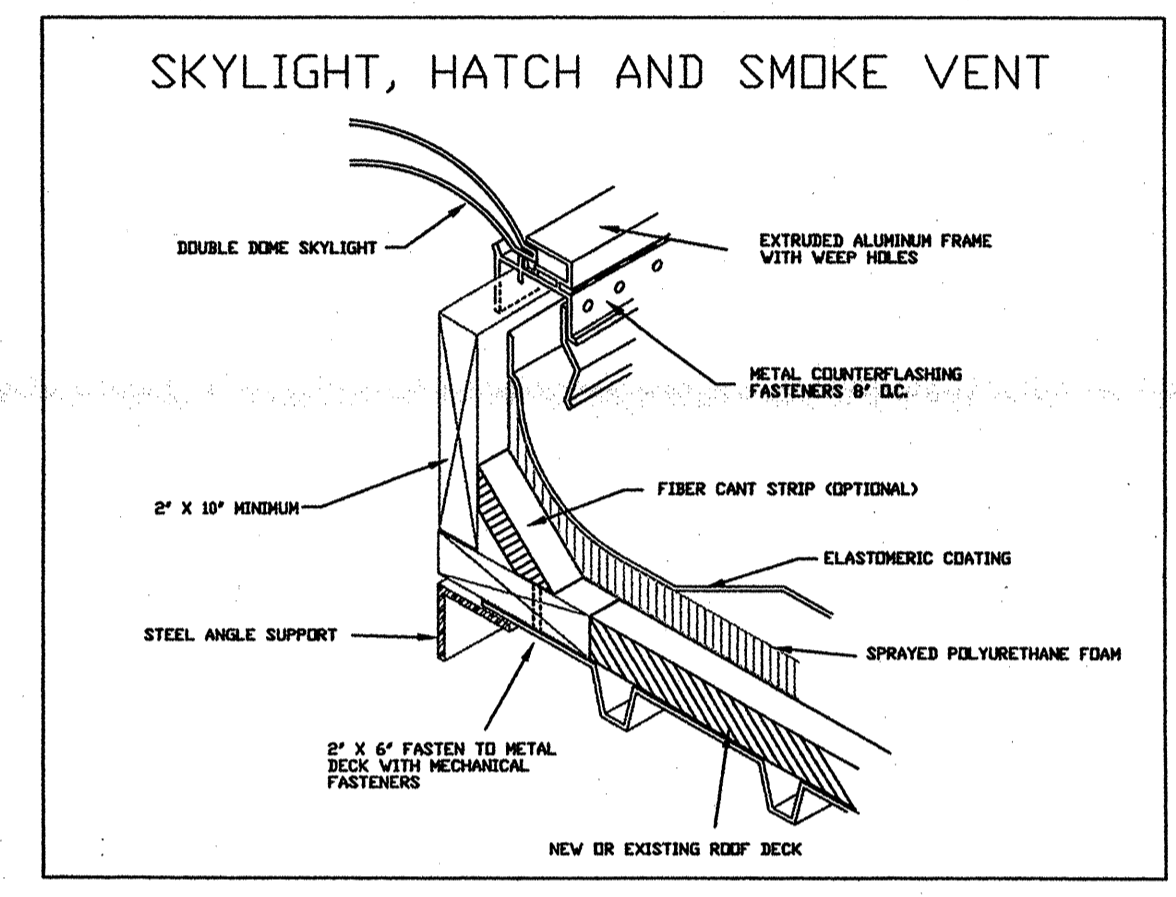

SKYLIGHT HATCH/VENT

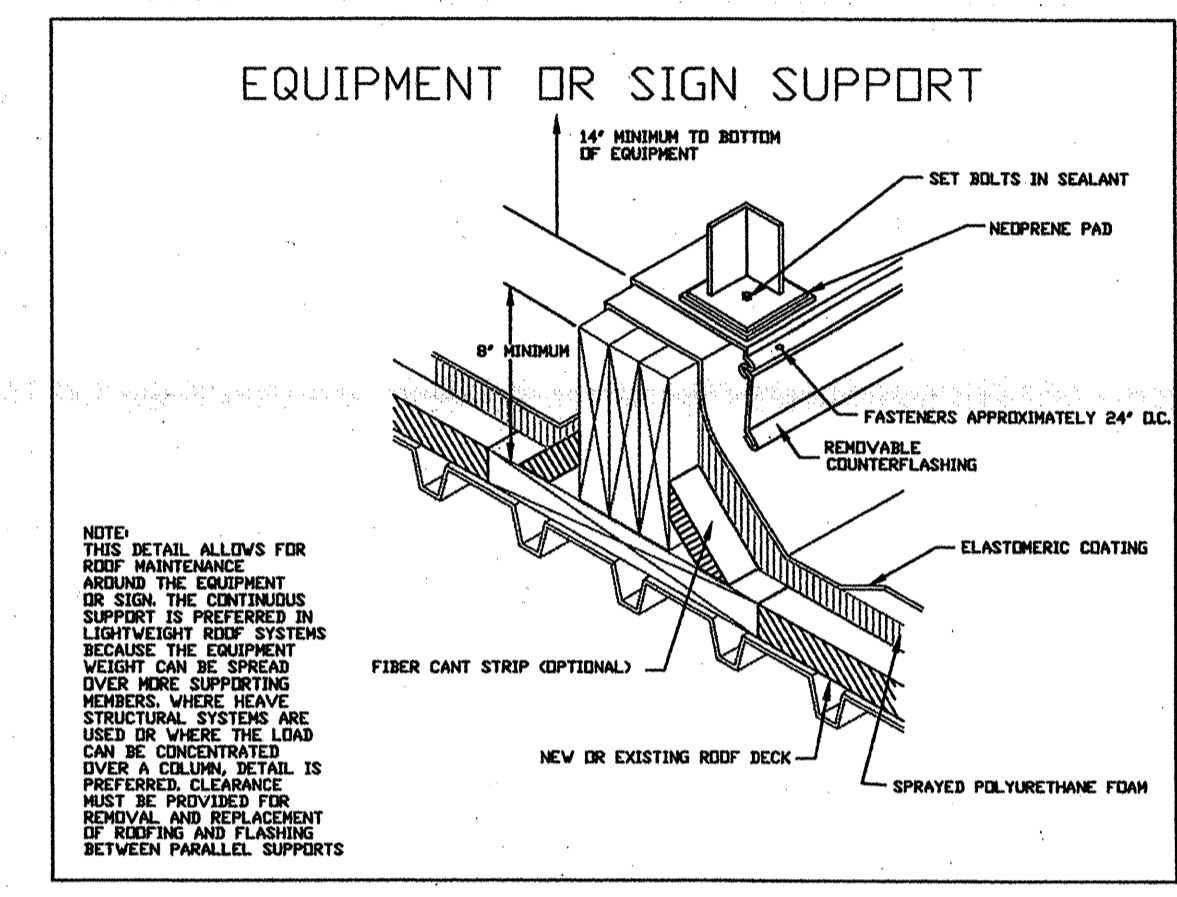

EQUIPMT / SIGN SUPPORT

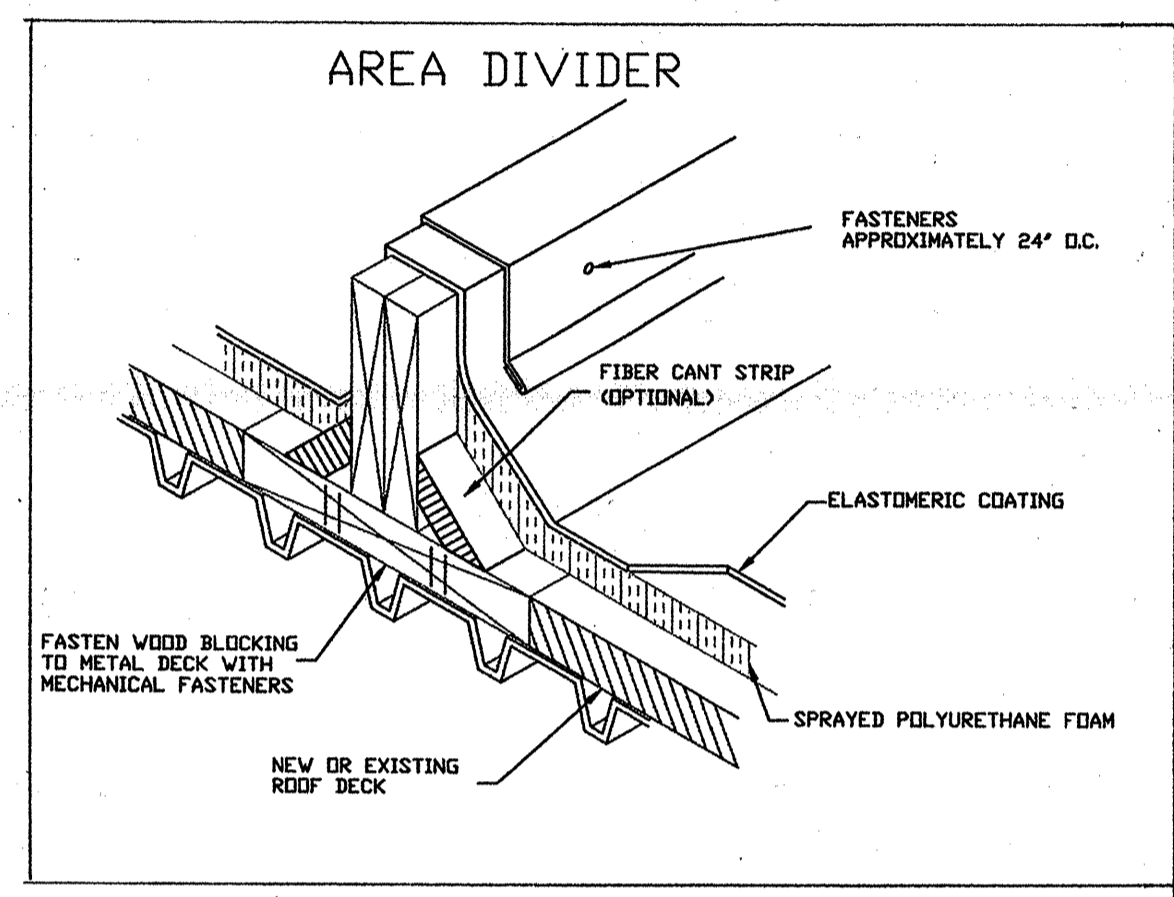

AREA DIVIDER

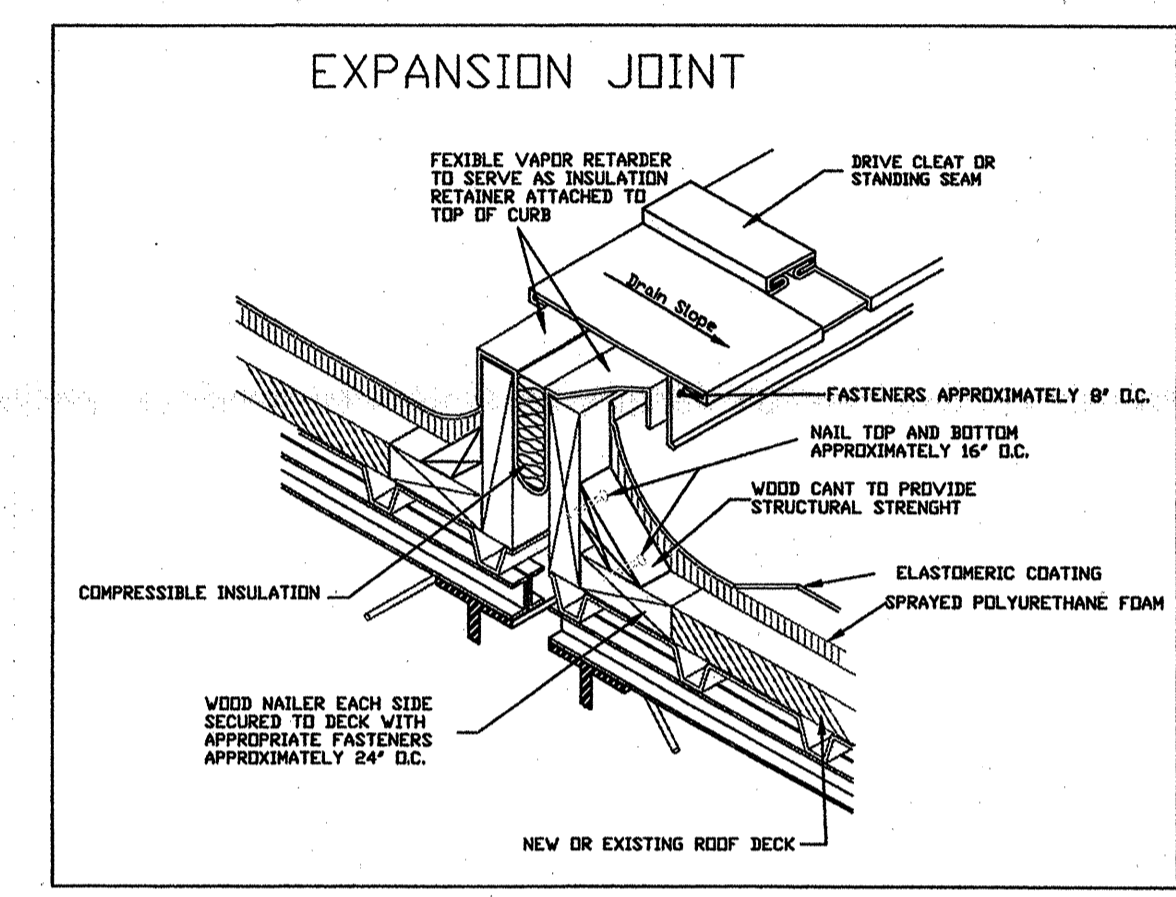

EXPANSION JOINT

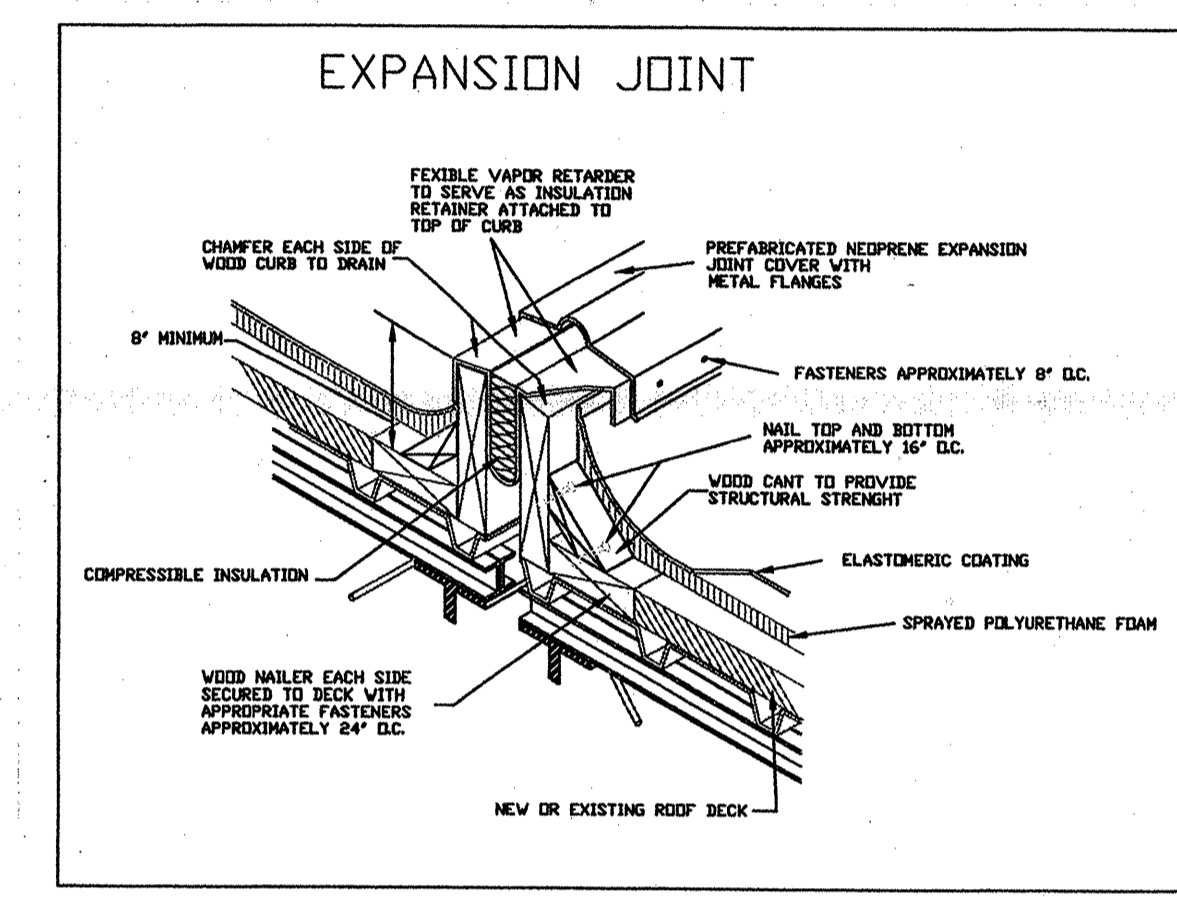

EXPANSION JOINT

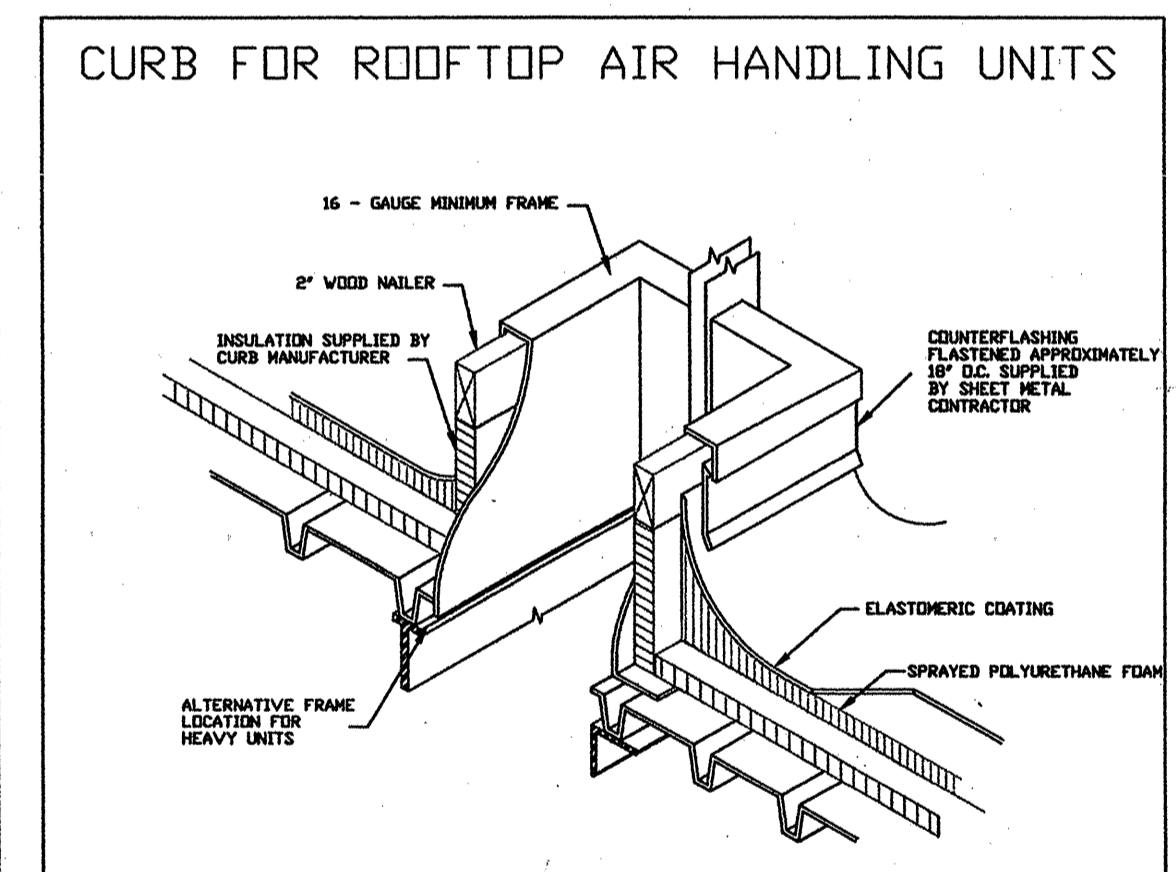

CURB @ AIR HANDLING UNITS

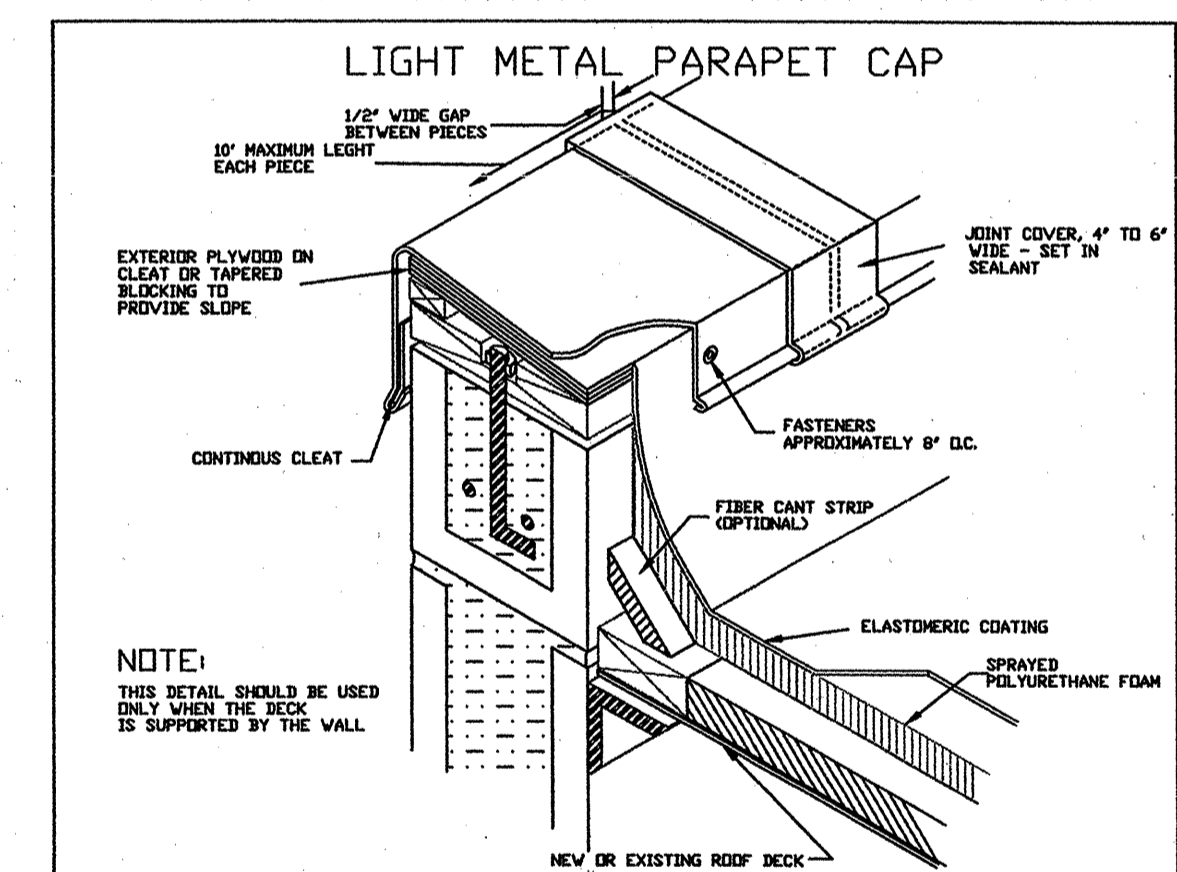

LIGHT METAL PARAPET CAP

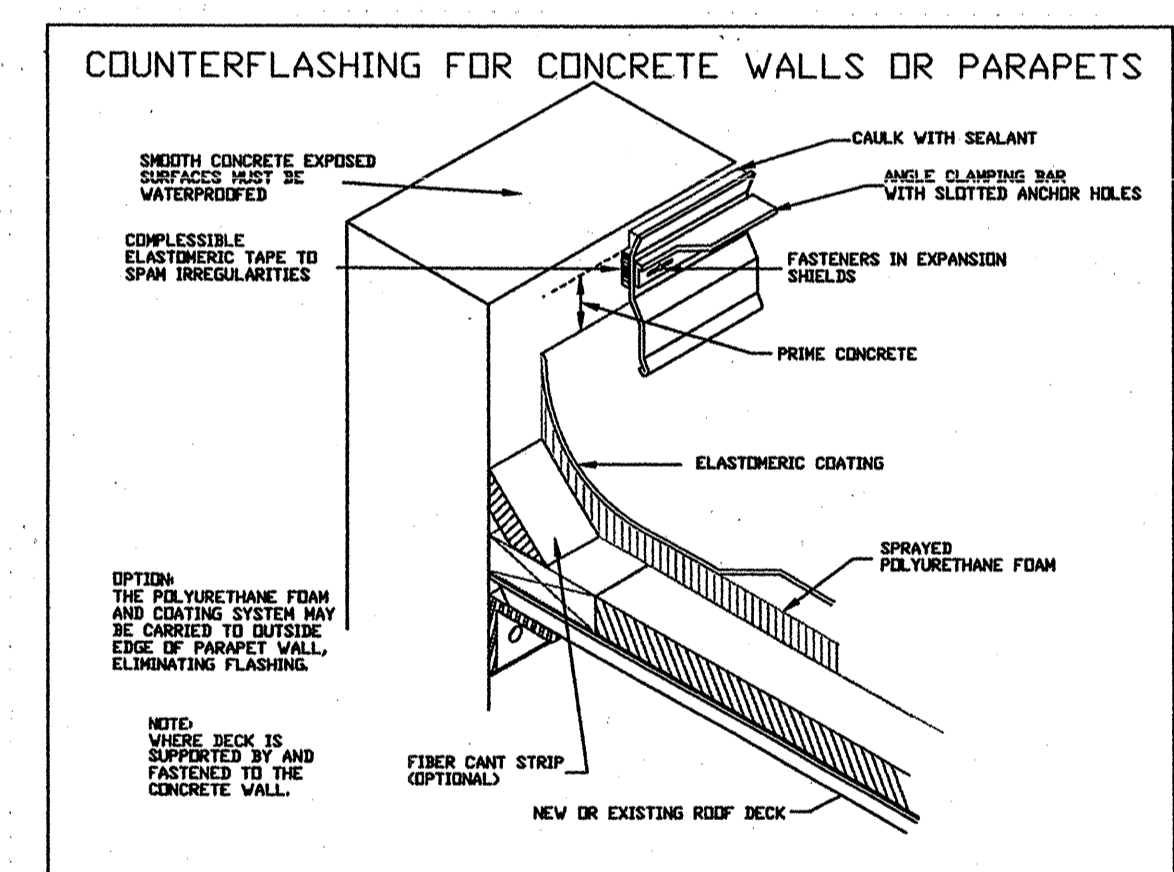

COUNTERFLASHING

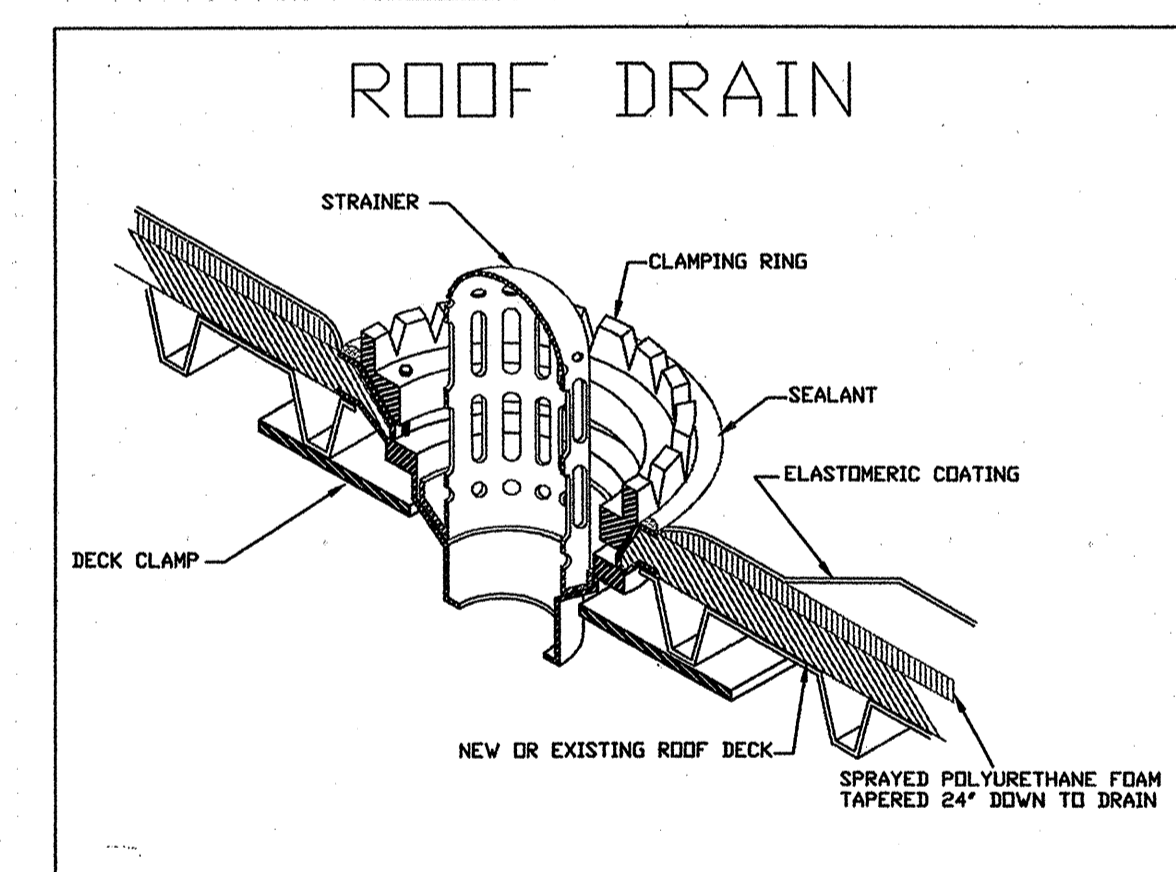

ROOF DRAIN

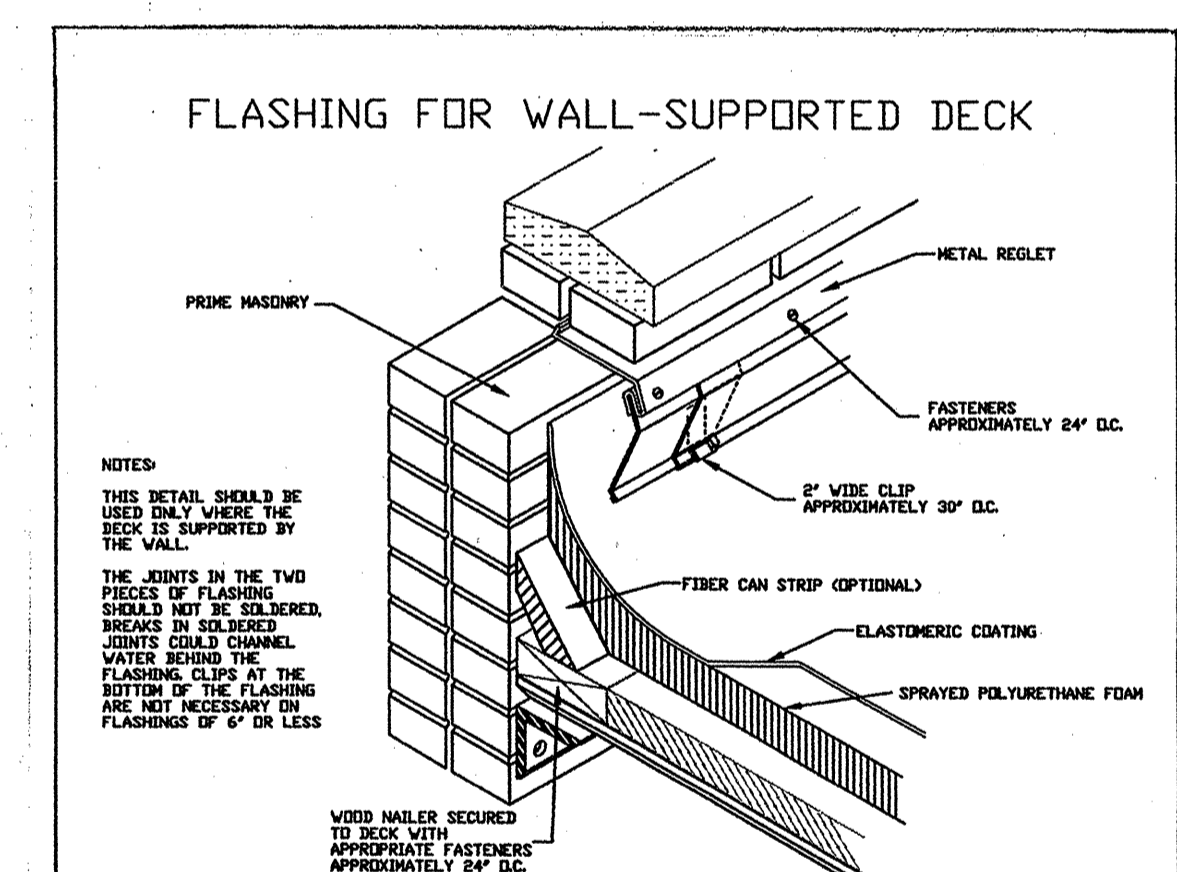

FLASHING @ DECK

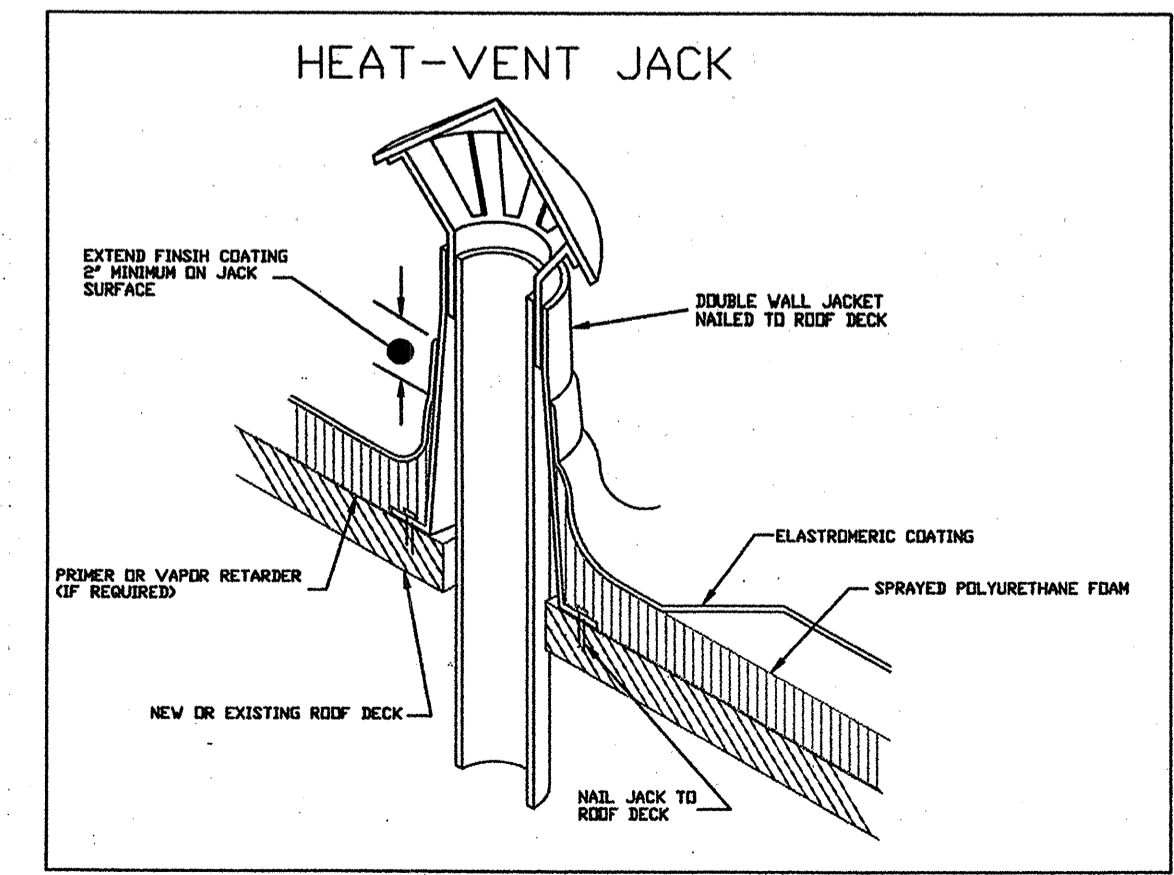

HEAT-VENT JACK

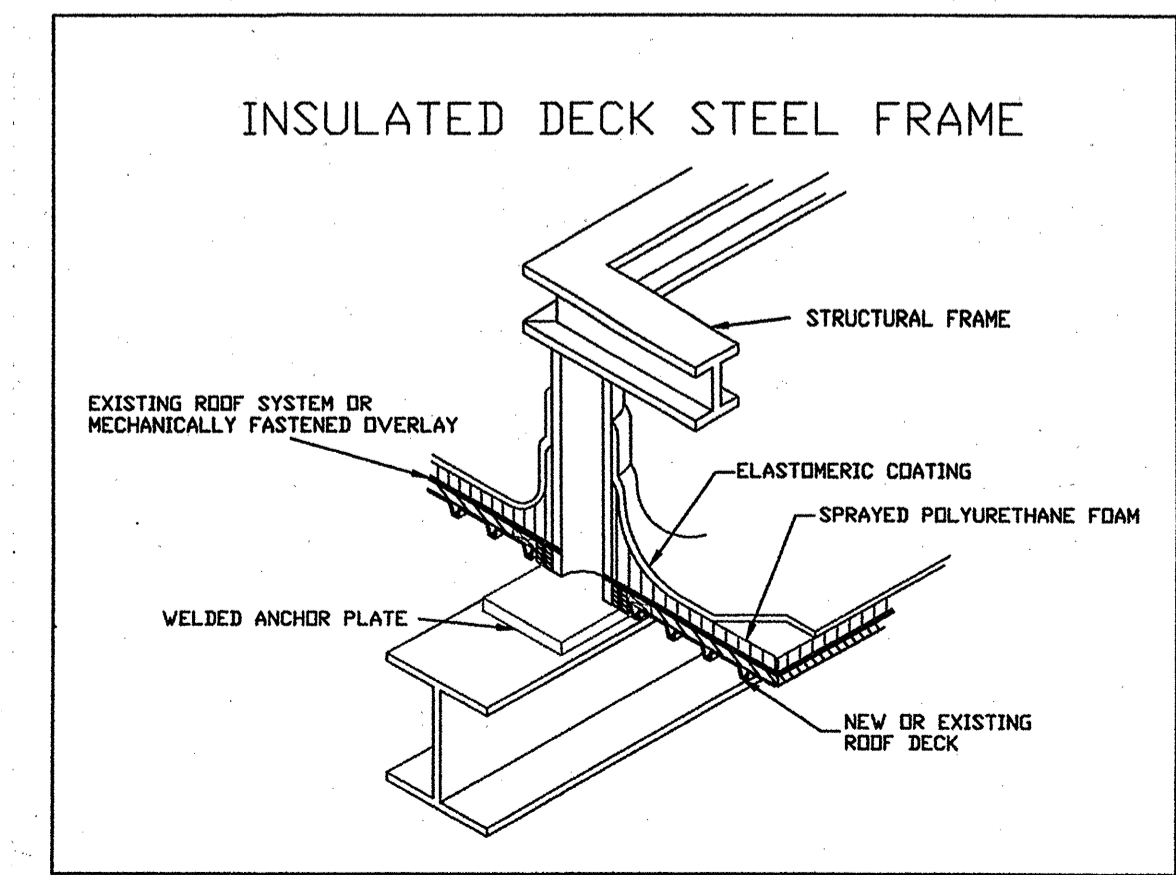

INSULATED DECK STEEL FRAME

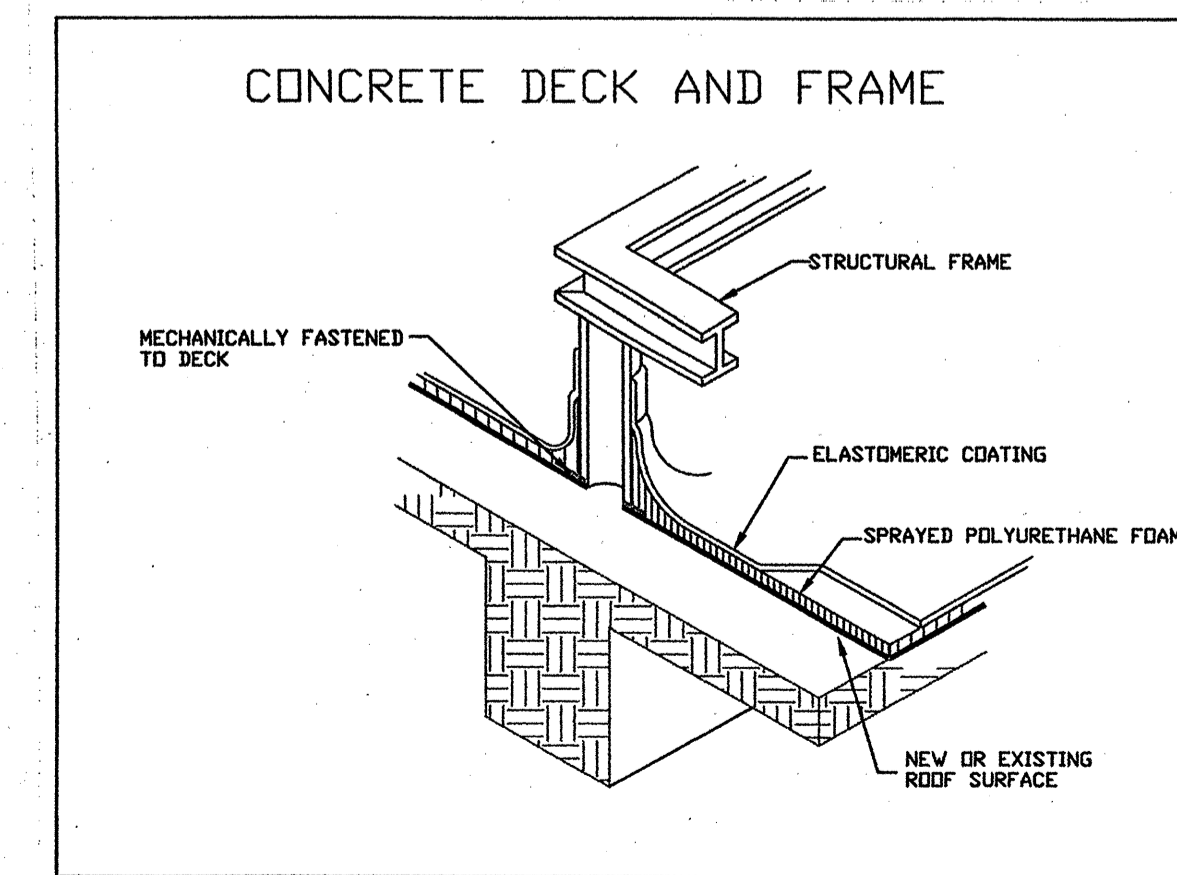

CONCRETE DECK & FRAME

NOTE: DETAILS SHOWN ARE TYPICAL DETAILS PROVIDED BY THE MANUFACTURER, G.E. ROOFING SYSTEMS

TYPICAL DETAILS: SILICONE / SPRAY POLYURETHANE FOAM (SPUF) ROOFING SYSTEM